

2M57-55A-0821

接线图  
Wiring Diagram

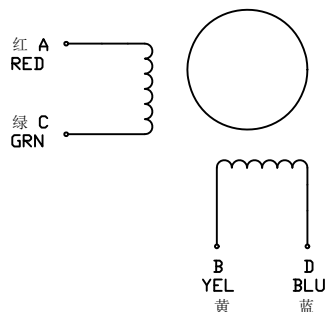

规格 SPECIFICATIONS

1	相数 Number of Phase	2
2	步距角 Step Angle	1.8° ±5%
3	保持力矩 Holding Torque	12 kg. cm
4	电压 Voltage	2.85VDC
5	电流 Current	3.0 A
6	相电阻 Phase Resistance (20°C)	0.95 ±10% Ω
7	相电感 Phase Inductance (1KHz)	2.8 ±20% mH
8	转子惯量 Rotor Inertia	280g · cm <sup>2</sup>
9	绝缘电阻 Insulation Resistance	100MΩ 500VDC
10	绝缘等级 Insulation Class	B (130°C)
11	环境温度 Ambient Temperature	-20°C to 50°C
12	环境湿度 Ambient Humidity	15% to 95%
13	电机重量 Motor Weight	Approx 0.65 kg
14		

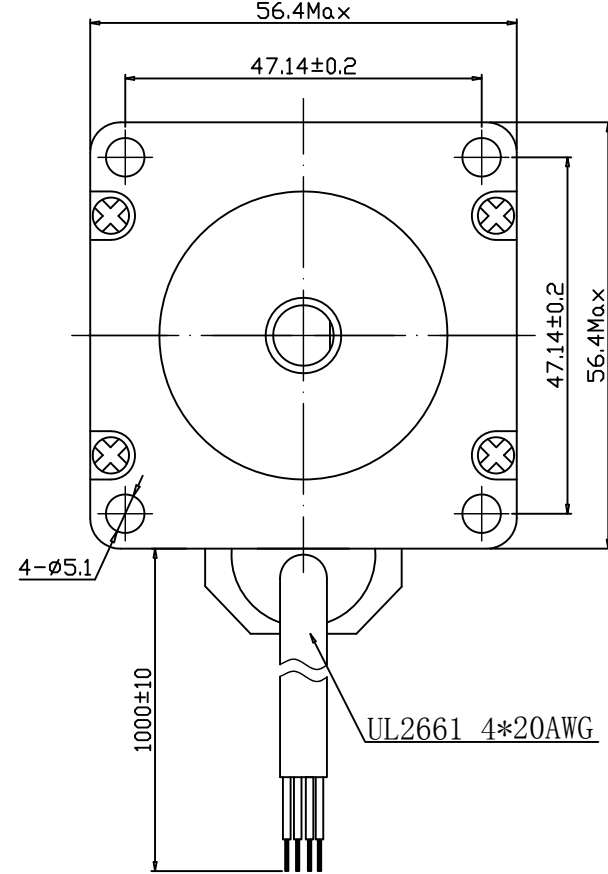
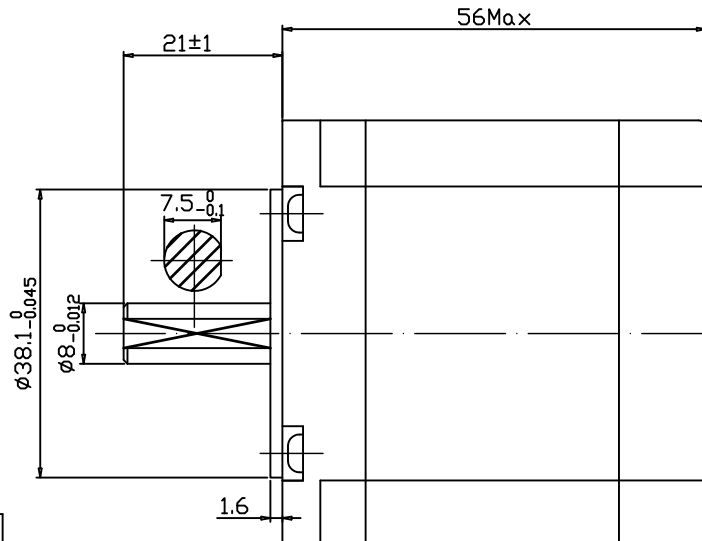

励磁顺序 (2相励磁)

EXITING SEQUENCE (2 PHASE)

STEP	A	B	$\bar{A}$	$\bar{B}$	CCW
1	+	+	-	-	↑
2	-	+	+	-	
3	-	-	+	+	
4	+	-	-	+	

↓ CW

NOTE: This document is released for information only. Its reproduction in whole or in part or its dissemination to third parties is prohibited. Unless otherwise specified all trademarks and registered trademarks appearing on this document are the property of changzhou chuangwei motor & electric apparatus co.,ltd.

Unit:mm  
第一角画法  
First angle method  
未注线性与角度尺寸公差  
Tolerances for linear and angular dimensions without individual tolerance indications  
GB/T 1804-m eqv ISO 2768-1:m  
未注形状与位置尺寸公差  
Geometrical tolerances for features without individual tolerance indications  
GB/T 1184-k eqv ISO 2768-2:k

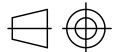

设计 DESIGN	HTX	21210721
校核 CHECK		
工艺 TECHNOLOGY		
标准化 STANDARD		
批准 APPROVE		
NAMES	SINGATURE	DATE

CW-motor



常州创伟电机电器有限公司

Changzhou Chuangwei Motor & Electric Apparatus Co.,Ltd

TYPE: HYBRID STEPPING MOTOR SCALE XX Rev. 1.0 SHEET 1 OF 1

Model : 57BHH56-300S-21Bi

V1.0	HTPS2107203	20210721
REV.	版本记录 REVISION RECORD	DATE