

接线图
Wiring Diagram

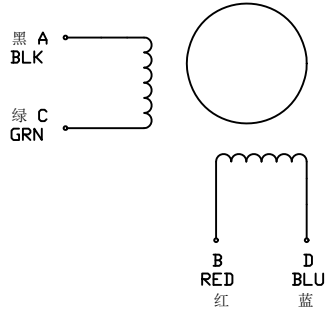

规格 SPECIFICATIONS

1	相数 Number of Phase	2
2	步距角 Step Angle	1.8° ±5%
3	保持力矩 Holding Torque	85 kg. cm
4	电压 Voltage	1.26 VDC
5	电流 Current	5.0 A
6	相电阻 Phase Resistance (20°C)	0.6 ±10% Ω
7	相电感 Phase Inductance (1KHz)	5.3 ±20% mH
8	转子惯量 Rotor Inertia	3800g · cm ²
9	绝缘电阻 Insulation Resistance	100M Ω 500VDC
10	绝缘等级 Insulation Class	B (130°C)
11	环境温度 Ambient Temperature	-20°C to 50°C
12	环境湿度 Ambient Humidity	15% to 95%
13	电机重量 Motor Weight	Approx 2.3 kg
14		

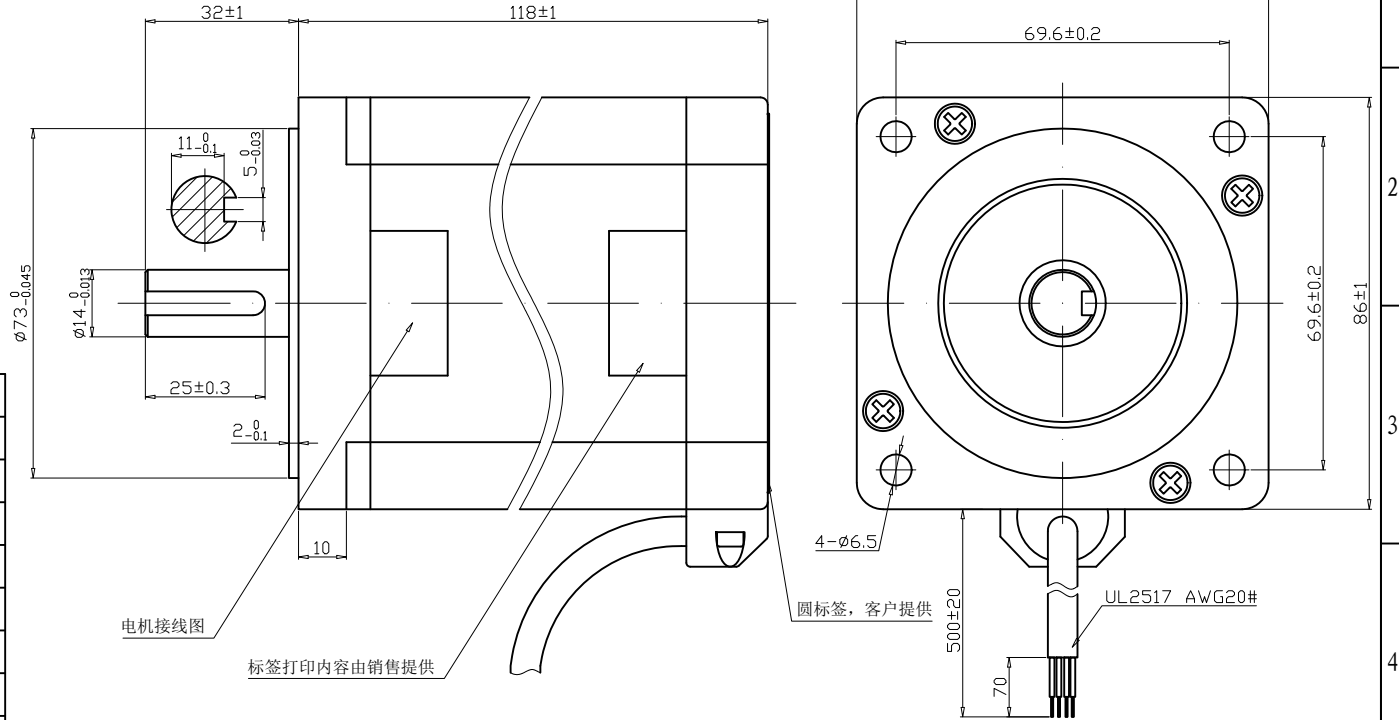

励磁顺序 (2相励磁)

EXITING SEQUENCE (2 PHASE)

STEP	A	B	\bar{A}	\bar{B}	
1	+	+	-	-	CCW
2	-	+	+	-	
3	-	-	+	+	
4	+	-	-	+	CW

NOTE: This document is released for information only. Its reproduction in whole or in part or its dissemination to third parties is prohibited. Unless otherwise specified all trademarks and registered trademarks appearing on this document are the property of changzhou chuangwei motor & electric apparatus co., ltd.

Unit:mm
第一角画法
First angle method
未注线性与角度尺寸公差
Tolerances for linear and angular dimensions
without individual tolerance indications
GB/T 1804-m eqv ISO 2768-1:m
未注形状与位置尺寸公差
Geometrical tolerances for features without
individual tolerance indications
GB/T 1184-k eqv ISO 2768-2:k

设计 DESIGN	XH	20180123
校核 CHECK		
工艺 TECHNOLOGY		
标准化 STANDARD		
批准 APPROVE		
NAMES	SINGATURE	DATE

CW-motor

常州创伟电机电器有限公司
Changzhou Chuangwei Motor & Electric Apparatus Co., Ltd

TYPE: HYBRID STEPPING MOTOR SCALE **XX** Rev. 1.0 SHEET 1 OF 1

Model: 86BHH118-501-Y32J①

V2.0	更改线色由RVV改为2517	20180226
V1.0	YJ1801231	20180123
REV.	版本记录 REVISION RECORD	DATE